



THERMORY
Excellence in Wood

INSTALLATION GUIDE

THERMORY[®] CLADDING



Thermory Ash cladding
Restaurant Noa, Estonia

1. Storage	3
2. Types of cladding	3
2.1 Horizontal cladding	3
2.2 Vertical cladding	3
3. Installation	4
3.1 Installation with screws	4
3.2 Installation with Thermory® hidden clips	5
3.2.1 B1-1	5
3.2.2 PaCS®	6
4. Battens	8
4.1 Horizontal cladding	8
4.2 Vertical cladding	8
5. Bottom fixing	9
6. Corner desing	9
7. Surface maintenance	10
8. Additional information	10

To ensure the most beautiful and truly long-lasting Thermory® cladding please follow the installation recommendations below.

1. Storage

Whenever possible, Thermory® cladding boards should be stored inside, out of the sun, rain and other elements. When this is not possible, boards need to be elevated off the ground, stacked uniformly and covered with a waterproof tarp. Leave the ends of the tarp open so moisture is not trapped inside, making certain the stored wood is not subjected to the elements or sun as UV rays will fade the material. Under no circumstances should Thermory® boards be subjected to rain or any moisture as they cannot dry properly when stacked and/or packaged.

2. Types of cladding

2.1 HORIZONTAL CLADDING:

- Thermory® profiles C1, C3, C4J, C6, C7, C7J, C8, C9, C11, C12 and C23J are meant for horizontal application.
- Tongue and groove boards (C1, C3, C8 etc.) have to be installed with the tongue pointing upwards.

SOME BASIC HORIZONTAL INSTALLATION POSSIBILITIES:

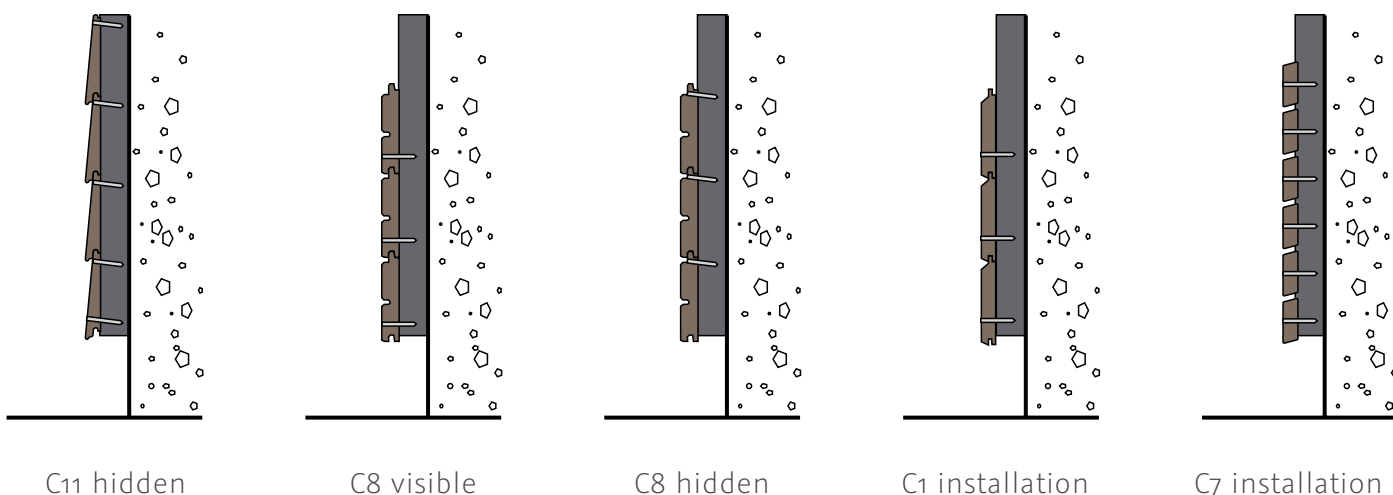

2.2 VERTICAL CLADDING:

- Thermory® profiles C1 and C3 are applicable also for vertical installation, profile C4 and C5 are applicable only for vertical installation.

SOME BASIC VERTICAL INSTALLATION POSSIBILITIES:

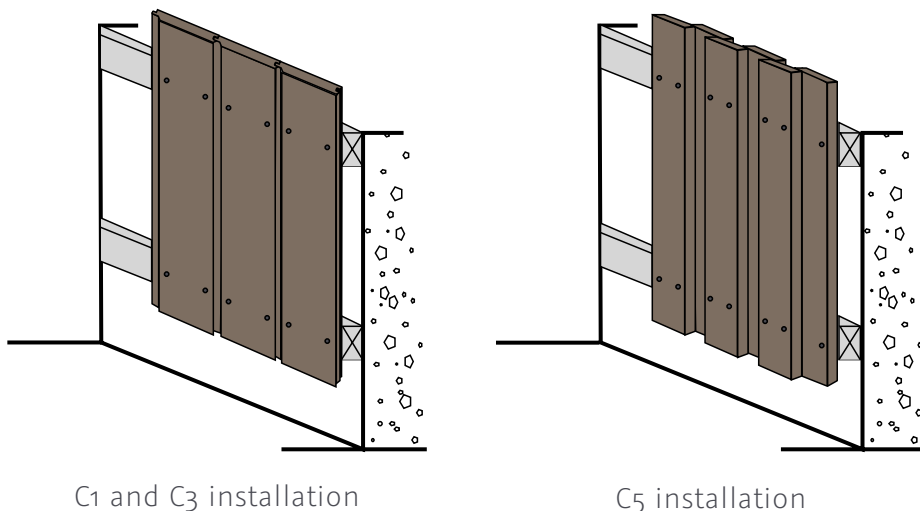

3. Installation

Always use stainless steel screws or Thermory® fastening clips when installing Thermory® cladding.

3.1 INSTALLATION WITH SCREWS:

- The pilot hole should be slightly larger in diameter than the screw itself to allow necessary movement and prevent splits. This holds in particular for Thermory Ash. Thermory Pine can be fixed with self-drilling screws.

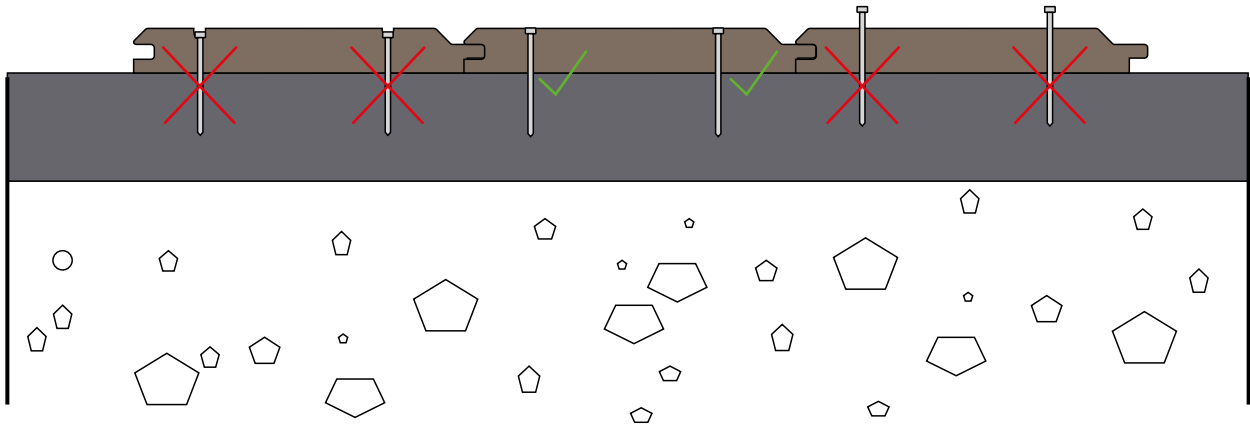

Screw heads must not penetrate too deep into the wood. Screw heads should fit snugly and be roughly level with the wood surface in order to reduce risk of water absorption.

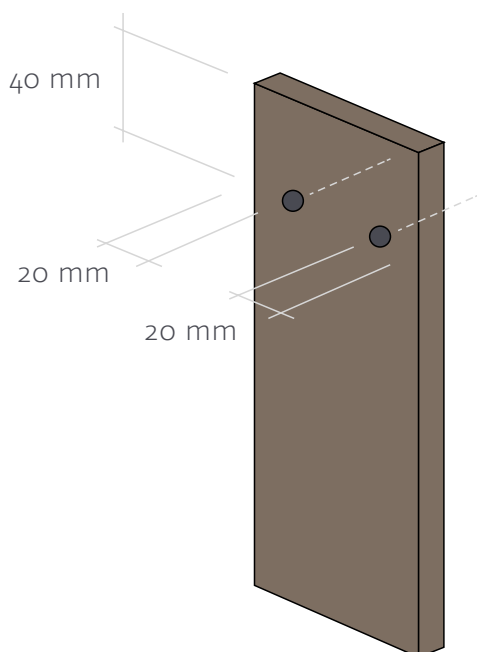

In order to avoid splitting of timber, leave approx. 20 mm space from the edge and 40 mm from the end of the board for drilling.

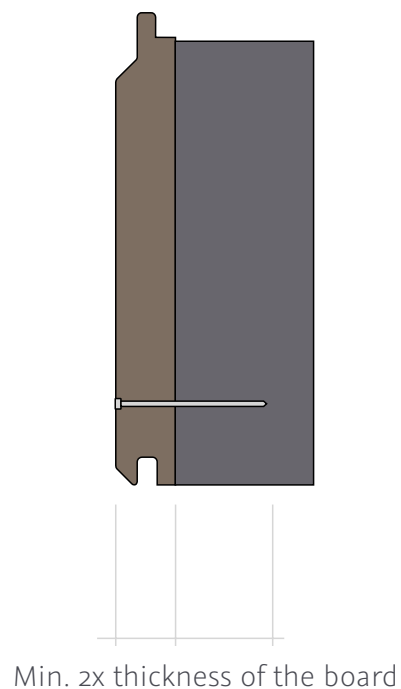

Length of screw/nail: minimum 2x thickness of the board at its thickest point.

3.2 INSTALLATION WITH THERMORY® HIDDEN CLIPS:

3.2.1 B1-1:

Thermory® stainless steel clip “B1-1” leaves a distance of 4 mm between the boards and is suitable for the following Thermory Ash cladding profiles: C6, C9, C92.

Estimated usage of clips: 1.7 pcs per running meter (considering battens are every 600 mm). Use stainless steel screws to attach the clips to the batten, 2 screws for each clip is enough. Clip “B1-1” available also with black coating.



Thermory® B1-1 clips

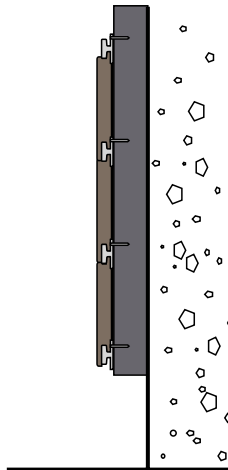

Installing C6 with B1-1 Thermory® clips

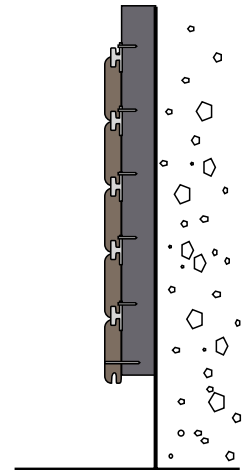

Installing C9 with B1-1 Thermory® clips

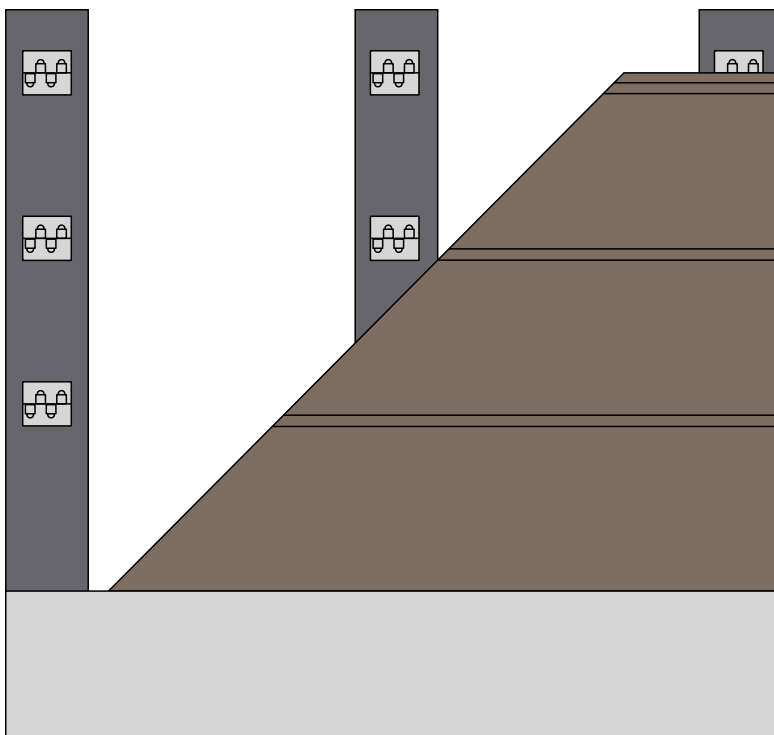

Installation with Thermory® B1-1 clips

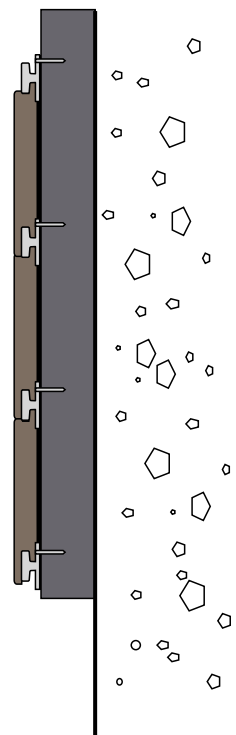

3.2.2 PACS®:

Thermory PaCS® is an innovative fastening solution designed for a quick and easy installation. It consists of specially profiled Thermory boards with a groove on the back side to perfectly fit the JuAn® clips. As a result, there are no visible screw heads, boards are just pressed and clicked into place.

PACS® Powered by [grad](#)

PaCS® cladding is available for profiles: C7J, C4J, C23J, C23J-6, C5J.

Thermory Ash
profile C23J

Thermory Ash
profile C4J

Thermory Pine
profile C7J

Thermory Clear Pine
profile C7J



The easiest and quickest fastening can be done by using Thermory CLAD solution: clad battens with already pre-mounted JuAn® single clips. Gap between the boards is 5 mm. CLAD batten length is 2.0 m.

JuAn® single clip by Grad is the most suitable fastener in cases where a bigger gap between boards is desired.

Suitable for cladding profiles C7J and C4J, C23J depending on width:

JuAn® single clip can be used with all PaCS® profiles and fixed according to specific requirements;

- CLAD52 is suitable for width 52 mm; 35 JuAn® single clips per clad.
- CLAD65 is suitable for width 65 mm; 28 JuAn® single clips per clad.
- CLAD65-o is suitable for width 65 mm; 31 JuAn® single clips per clad.
- CLAD72 is suitable for width 72 mm; 25 JuAn® single clips per clad.
- CLAD150 is suitable for width 150 mm; 28 JuAn® single clips per clad.

- The tested tearing strength of JuAn® single clip is 160 kg.
- The countersink screw needed for JuAn® single clip is 4.0 x 25 mm.
- Screws must be placed vertically and should not be over drilled.

PACS® CLADDING INSTALLATION

1. ASSEMBLY MATERIALS



You will need:

- a power drill
- wood screws
- a spirit level
- CLAD battens

2. FIXING CLAD BATTENS



Make sure you start all rows of clips in alignment.

Leave 600 mm distance between battens.

3. "PRESS AND CLICK"

Simply "Press and Click" the boards into place!



REQUIRED AMOUNT OF FASTENERS

→	pcs/rm	pcs/sqm	pcs per pack
JuAn® single clip	1.7	x	1000
CLAD52	x	0.94	196
CLAD65	x	0.94	196
CLAD72	x	0.94	196
CLAD150	x	0.94	196

* distance between the battens is 600 mm. All CLAD battens are 2.0 m in length.

4. Battens

We recommend using Thermory Spruce with resistance class 1. Battens must be placed no more than 600 mm apart. Ventilation should be provided behind the boards.

4.1 HORIZONTAL CLADDING

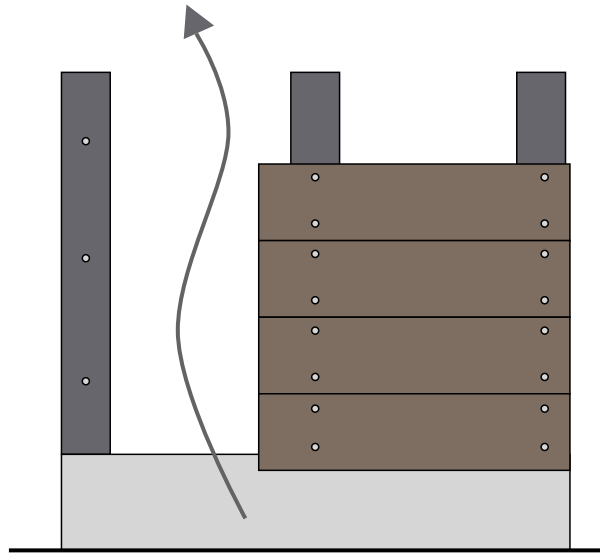

Fix horizontal cladding to vertical battens; the joint of the board must sit on the batten. If end-matched material is used, the joint can also be placed between the battens.

4.2 VERTICAL CLADDING

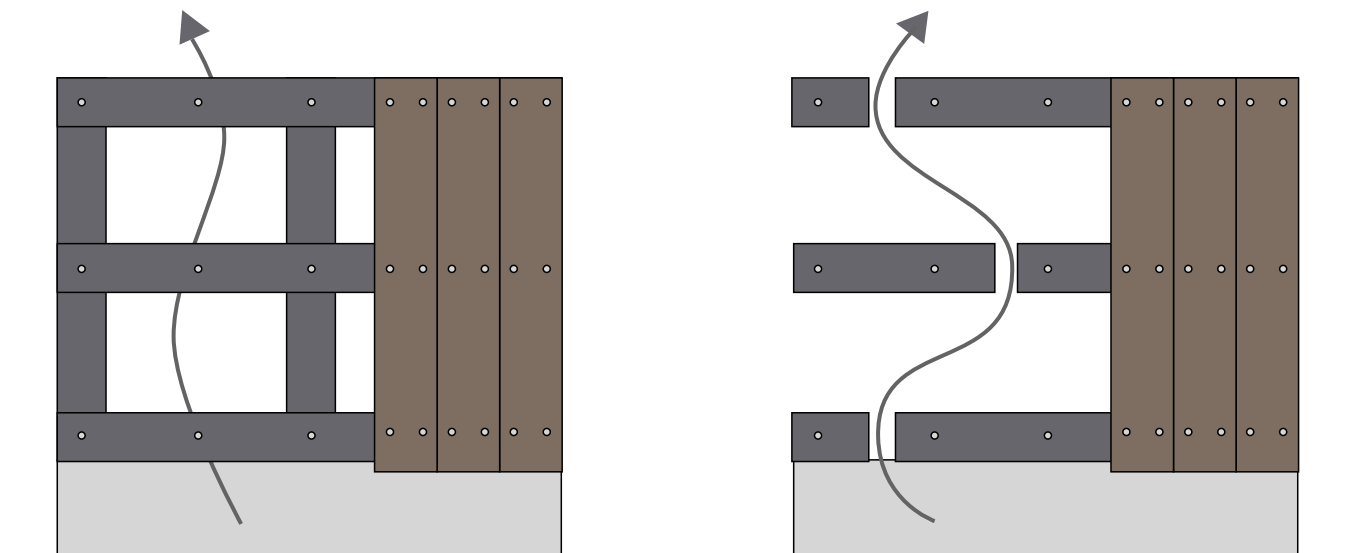

Fix vertical cladding to horizontal battens; the joint of the board must sit on the batten. If end-matched material is used, the joint can also be placed between the battens.

5. Bottom fixing

It is recommended to leave a minimum 300 mm gap between the ground and cladding. The ventilation gap behind the cladding must stay open from below to ensure air circulation.

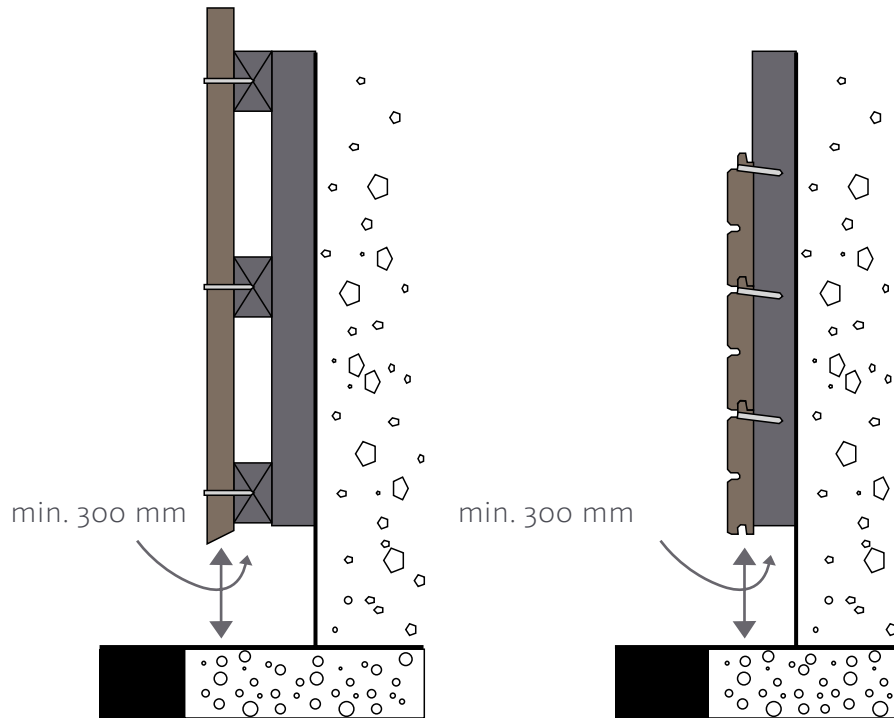

6. Corner design

- External and internal corners

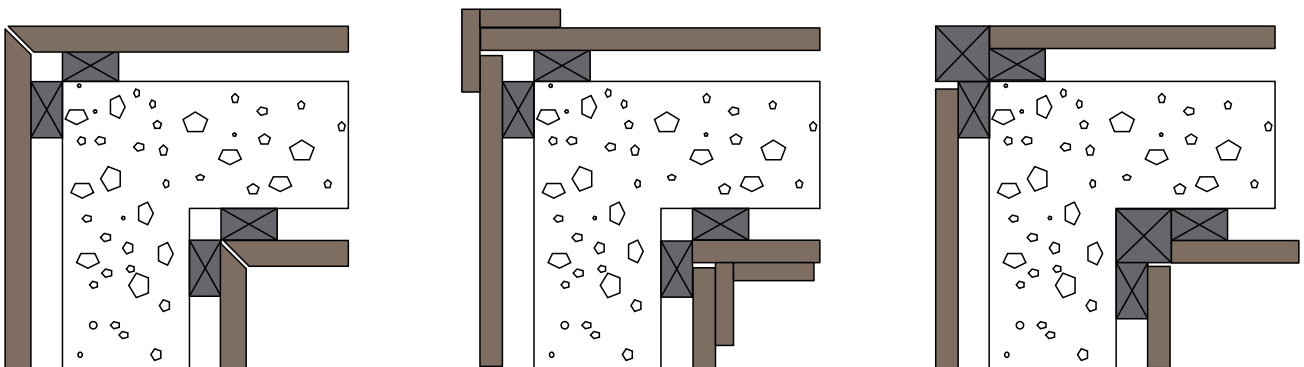

Some ideas for external and internal corners

7. Surface maintenance

Thermory® cladding does not require surface treatment. However, as with any wood, Thermory Ash and Thermory Pine will naturally age to a uniform silver/grey over time. This process will start immediately and, depending on the amount of UV exposure, will take anywhere from several months to a year. This does not make the wood any less resistant to decay.

To minimize color changes, Thermory® cladding can be protected by applying regular UV oil or pigmented UV mineral oil. Natural oils are not recommended as they contain substances that are a food source for biological organisms such as bacteria, mold, etc. Oil can only be applied to clean even dust-free surfaces. Apply a small amount of oil to a small piece of wood to test the color before coating the entire board. Oil manufacturer's guidelines for the treatment should be followed.

8. Additional information

These guidelines are purely informative, based on the best knowledge currently available, and should be used accordingly. Should the general recommendations of this brochure vary from the ones valid in your country, we advise you to follow your country's regulations.

Last updated: September 2017.
All previous versions are null and void.



Thermory Ash cladding
Hospital in Denmark